

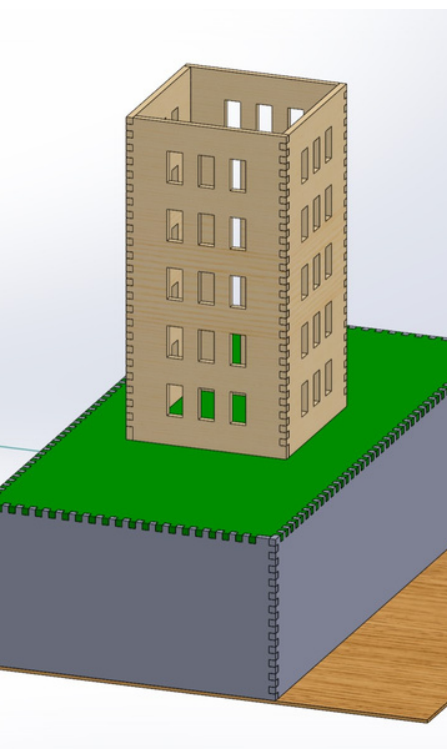

# Contents

Experience Level: the more stars, the more experience recommended

- 01 Connect With us
- 02 Sign Up for RAS
- 03 Outreach/Socials
- 04 Robotathon (Beginners)
- 05 Demobots ★
- 06 RoboMaster ★★ ★
- 07 Vex U ★★ ★
- 08 IGVC ★★ ★
- 09 Corporate Committee
- 10 Leaders Bulletin



# Connect With Us



Office: EER 0.822C



Website: [ras.ece.utexas.edu](http://ras.ece.utexas.edu)



MS Teams: [tinyurl.com/RASTeams](https://tinyurl.com/RASTeams)



@ut\_ieee\_ras



[ras.ece.utexas.edu/calendar.html](http://ras.ece.utexas.edu/calendar.html)



Discord: <https://discord.gg/KDzBwFn>



[github.com/ut-ras](https://github.com/ut-ras)



[facebook.com/groups/ut.ieee.ras/](https://facebook.com/groups/ut.ieee.ras/)

Link for Linktr.ee



Whether you're after something casual or technical, RAS is the place for you. Our projects are all do-able and we welcome students from any background!





# Join RAS!

**Sign Up at a General  
Meeting  
or at EER 0.822**

Dues: \$15 semesterly

○ ————— ○  
**ALL MAJORS  
ARE  
WELCOME!**  
○ ————— ○



# Outreach

- FLL Build Day-
- Gone to Engineering-
- Introduce a Girl to Engineering Day-



# Social Events

- Video game nights-
- Arcade nights-
- Movie nights-
- and more!





# Robotathon

Robotathon is the annual introductory robotics competition, that teaches the basics of robotics to those new (or used) to the field.

Join the steering committee to design and prototype the field and competition for the upcoming year!



# Demobots

Demobots is one of RAS's non-competitive committees, where RAS members can get involved in a variety of student-led robotics projects. This semester we will be working on the Dancebot, Couchbot, Catchbot, and a Claw Machine (lovingly called Talons of Aquisition).

PAGE 5

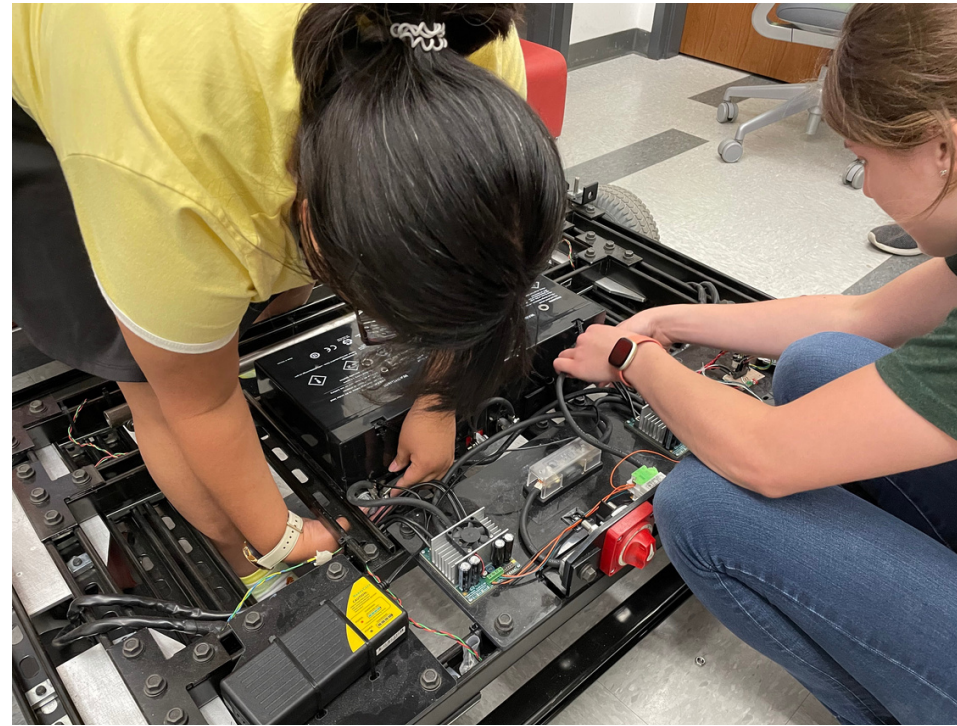
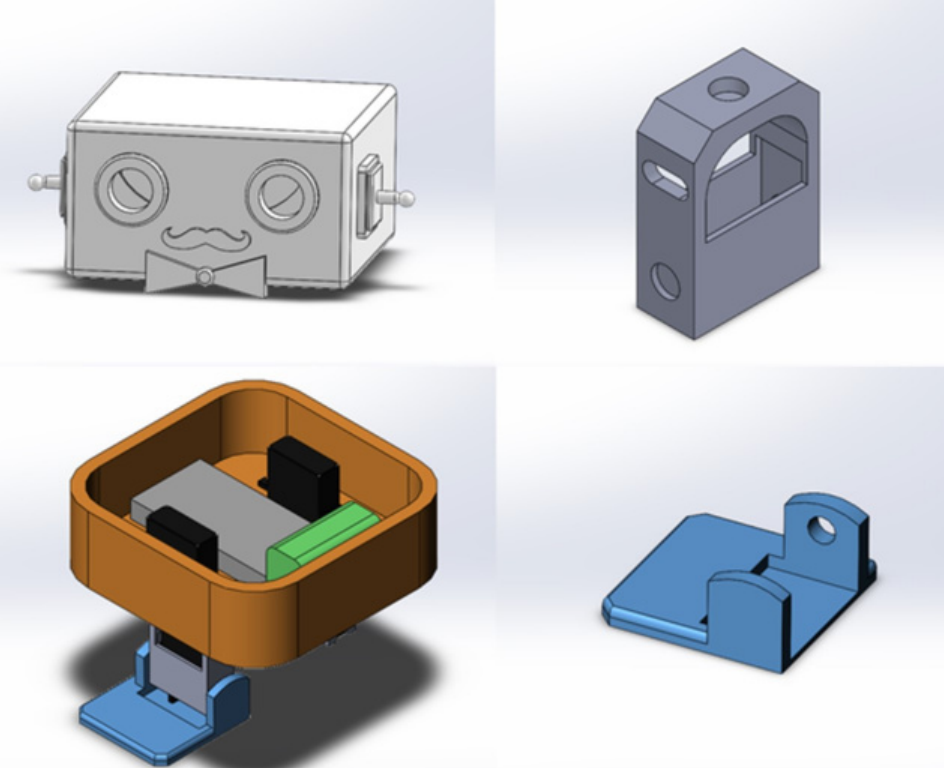



# STAMPEDE

ROBOMASTERUT

## RoboMasters

RoboMaster is an intercollegiate robot competition that recently expanded into the North American region. Students build and program three robots with auto-aiming software to participate in this video game inspired competition. In collaboration with coalition partners, our team recently played and scored fourth in 3v3s at Robomaster University League North America hosted at Texas A&M.





# Vex U

VEX U is a subdivision of the VEX Robotics competition, which boasts more than 20,000 teams from 50 countries playing in more than 1,700 competitions annually. This year we are developing two robots to compete in a frisbee golf variant against other universities' teams. Students have the opportunity to engage with the full lifecycle of robot design, starting with an initial idea, iterating on their mechanical, electrical, and software designs over the course of the season, and culminating in a completed robot that competes in both autonomous and teleoperated challenges.

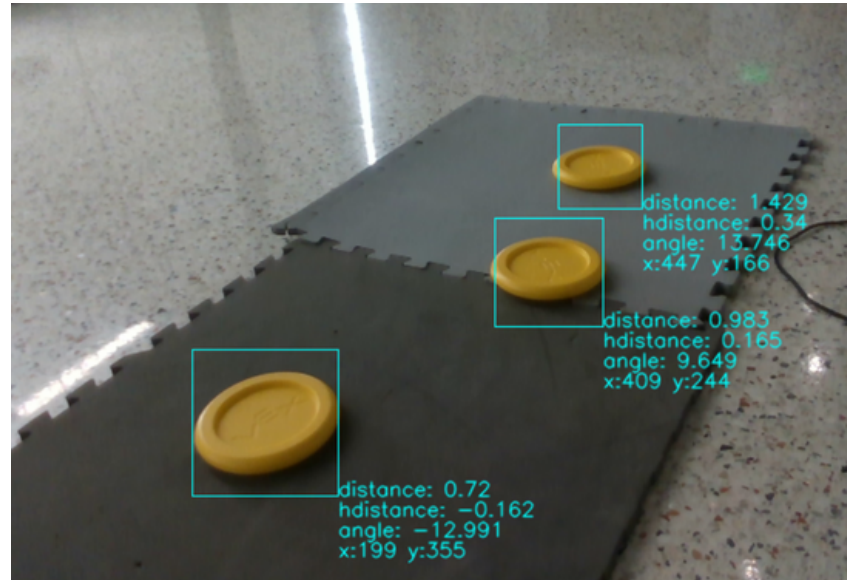
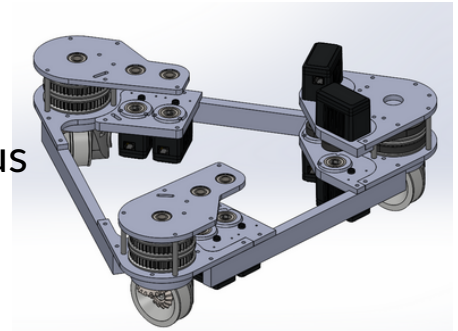
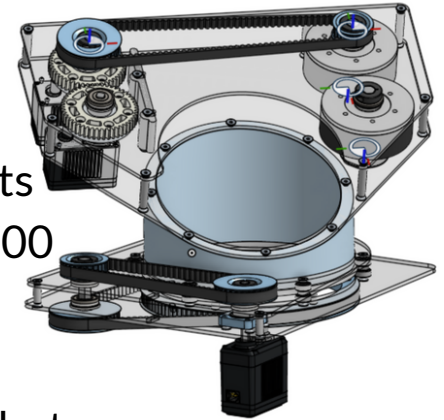

# IGVC

IGVC is an annual competition where teams design and build an autonomous ground vehicle capable of completing several difficult challenges.

We are looking for:

1. EEs interested in learning how to make hardware designs
2. MEs to train in CAD suites for future upgrades and machining experience
3. CS/EE majors who want to learn ROS Python to program our navigation algorithms involving sensor fusion

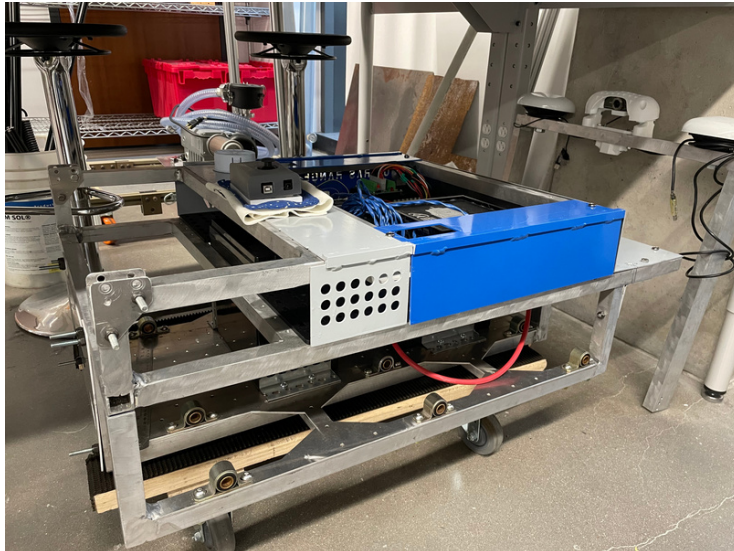

The background is a collage of two photos. The left photo shows a person sitting on a bed with a white blanket, using a laptop. The laptop screen displays an email interface. A smartphone is visible on the bed next to the laptop. The right photo shows a person in a blue denim shirt sitting at a wooden desk, writing in a notebook with a black pen. A laptop is open on the desk next to the notebook. A woven basket containing scissors is in the foreground of the right photo.

**CORPORATE AND  
FUNDRAISING  
COMMITTEE**

**RECRUITING  
REPRESENTATIVES**

CONTACT:

Wenyu Zhu for Corporate  
Devan Romero for Fundraising

PAGE 9

# LEADERS BULLETIN

<b>President</b>	<b>Wendy Rodriguez Ovalle</b>
<b>Vice President</b>	<b>Yuqi Pan</b>
<b>Treasurer</b>	<b>Faith Leake</b>
<b>Secretary</b>	<b>Eddie Liao</b>
<b>Director of Corporate Relations</b>	<b>Wenyu Zhu</b>
<b>Outreach Coordinator</b>	<b>Purva Kantawala</b>
<b>Special Events Coordinator</b>	<b>Reiko Corteza</b>
<b>Fundraising Coordinator</b>	<b>Devan Romero</b>
<b>Historian</b>	<b>Paul Han</b>
<b>Webmaster</b>	<b>Dario Jimmenez</b>
<b>Robotathon Head</b>	<b>Rosanna Rincon</b>
<b>Demobots Head</b>	<b>Caitlin Montgomery</b>
<b>Robomasters Head</b>	<b>Yuqi Pan</b>
<b>Vex U Head</b>	<b>Maxx Wilson</b>
<b>IGVC Head</b>	<b>Peter Mathews</b>
<b>Faculty Advisor</b>	<b>Jonathan Valvano</b>